

*Made in Holland*

**PITT**  
COOKING



**Gas**  
*Bennett*  
*Top Side*

## Exploded view

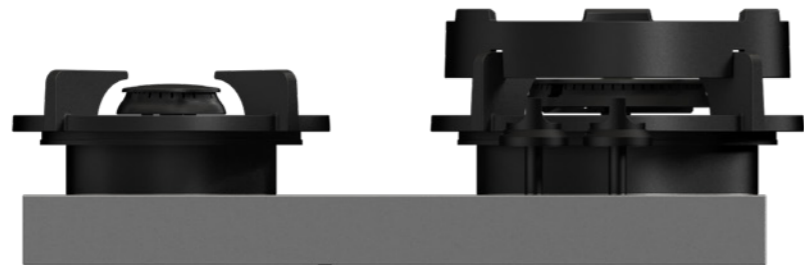
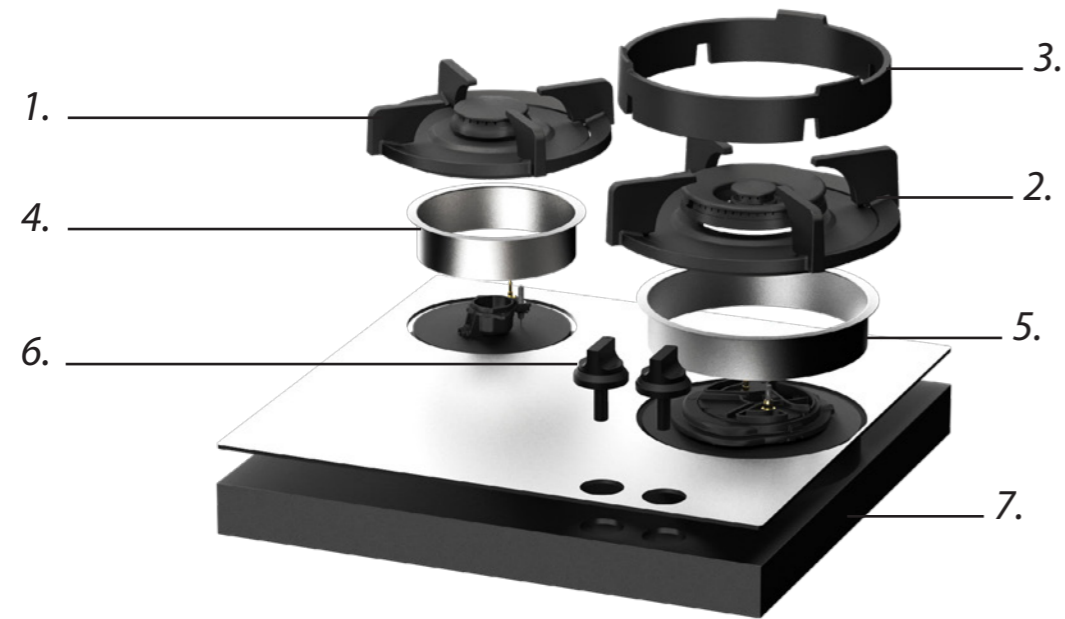

1. **Small burner**  
ENAMELED CAST IRON

2. **Wok-/simmer burner**  
ENAMELED CAST IRON

3. **Wok ring**  
ENAMELED CAST IRON

4. **Flange**  
STEEL

5. **Heat conductor**  
ALUMINIUM

6. **Control knob**  
ANODISED ALUMINIUM

7. **Cassette unit**  
GALVANIZED STEEL

## Burners

Small burner

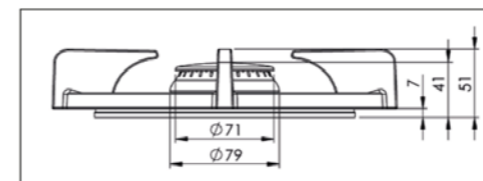
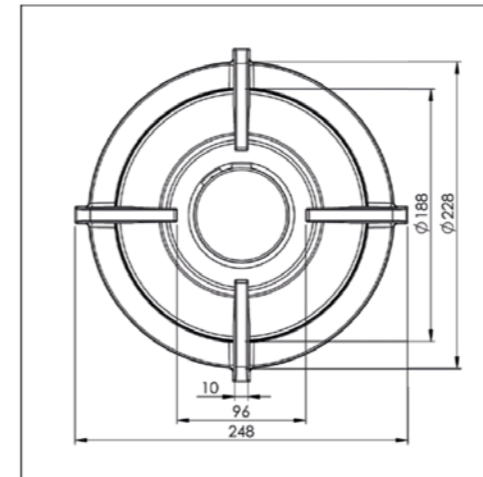

**SMALL BURNER**

MIN. POWER  
**0,3 kW**

MAX. POWER  
**2 kW**

DIAM. BURNER  
**Ø 230 mm**

Wok-/simmer burner

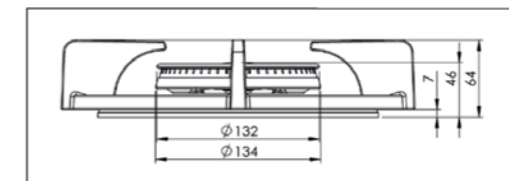
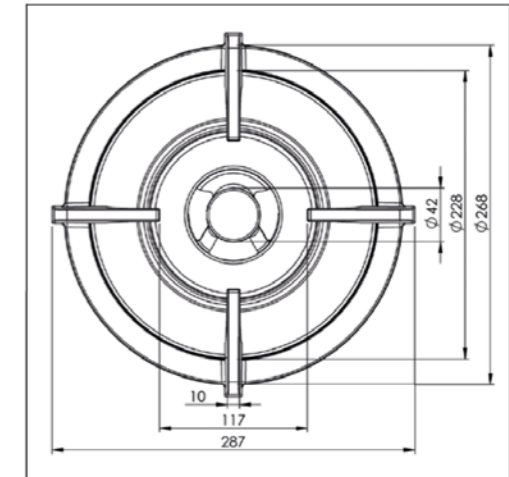

**WOK-/SIMMER BURNER**

MIN. POWER  
**0,2 kW**

MAX. POWER  
**5 kW**

DIAM. BURNER  
**Ø 270 mm**

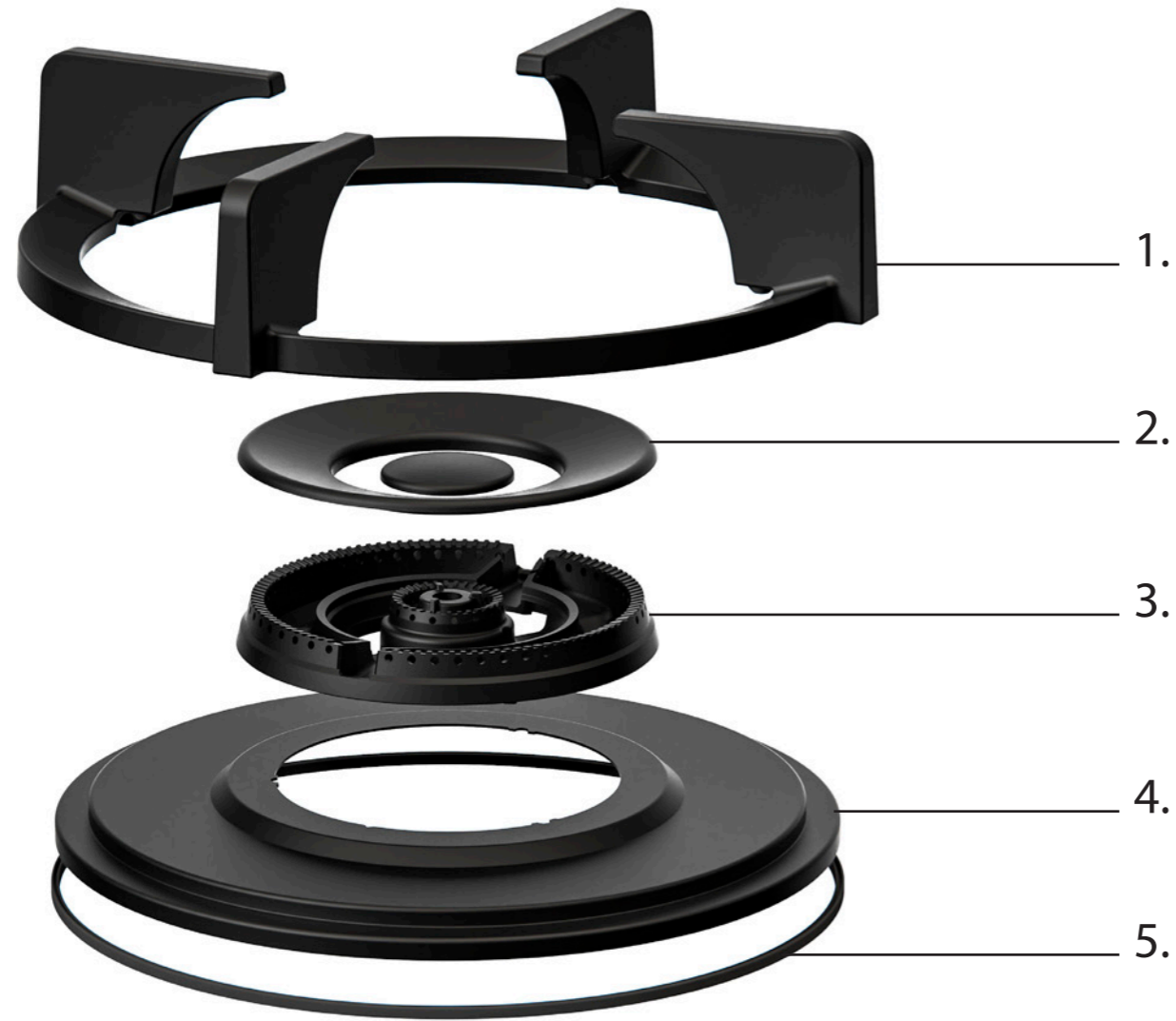

1. **Pan support**  
ENAMELED CAST IRON

2. **Burner caps**  
ENAMELED CAST IRON

3. **Flame spreader**  
(COATED BRASS)

4. **Heat shield**  
ENAMELED STEEL

5. **Silicone ring**  
SILICONE

**Professional edition**  
HEAVY BRASS BURNERS.  
FOR THOSE WHO WANT TO COOK IN STYLE



SMALL BURNER

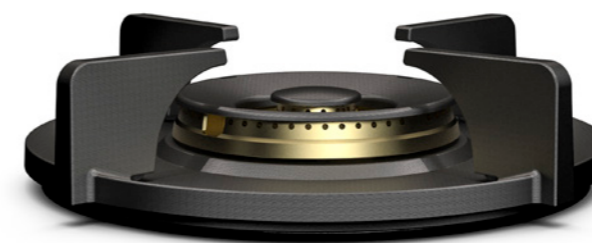

WOK-/SIMMER BURNER

**Black edition**  
HEAVY BRASS BURNERS.  
BLACK BURNERS WITH A BLACK SURFACE.  
STYLISH AND REFINED.



SMALL BURNER



WOK-/SIMMER BURNER

## Control knob Top Side

3D-image Top Side knob

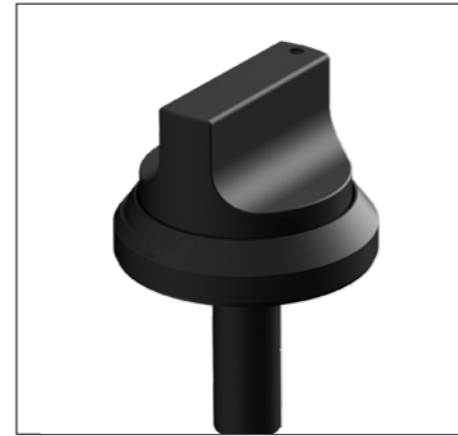

Front view Top Side knob

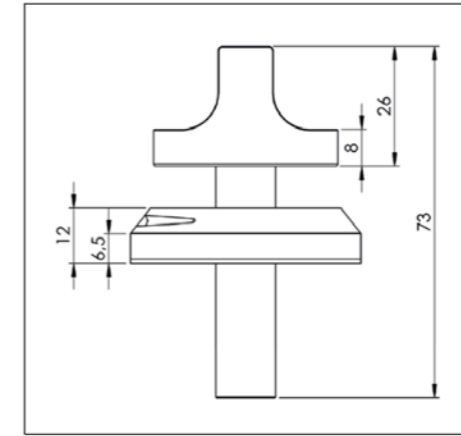

Top view Top Side knob

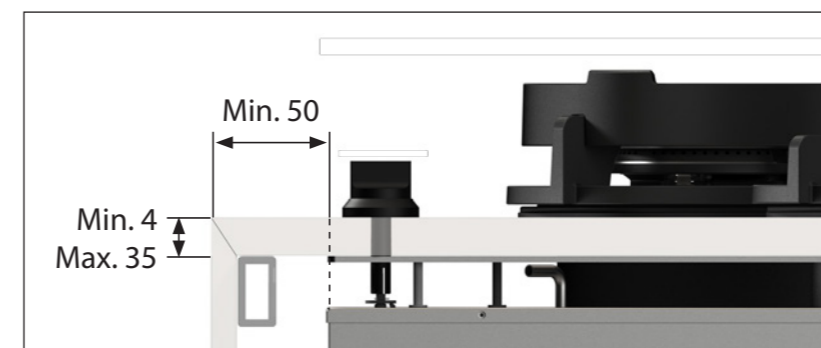
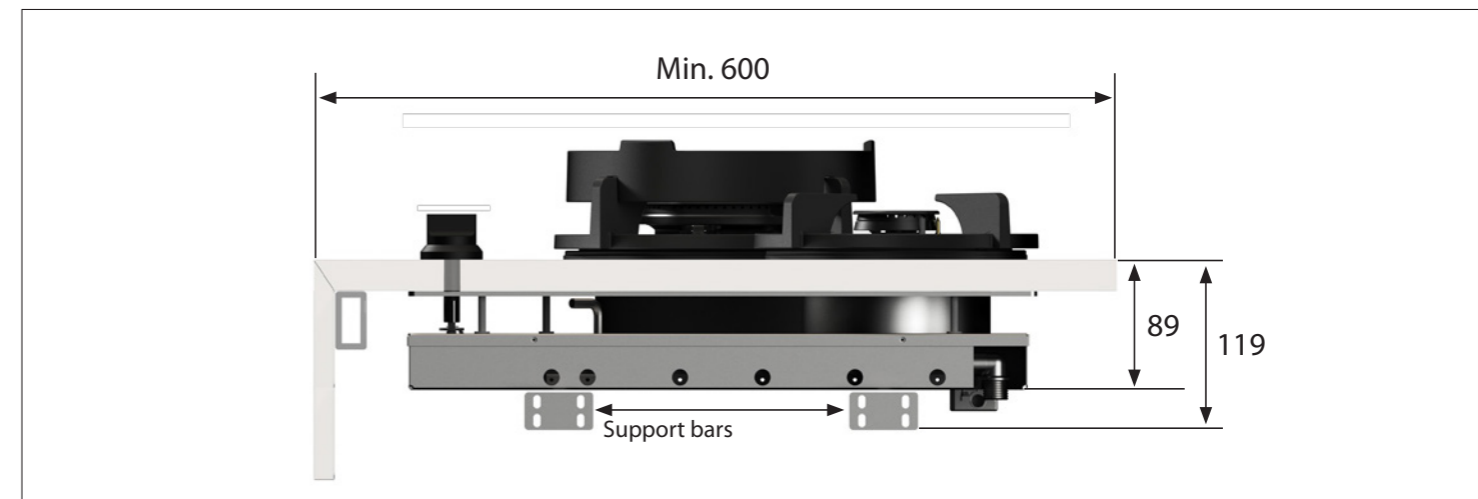
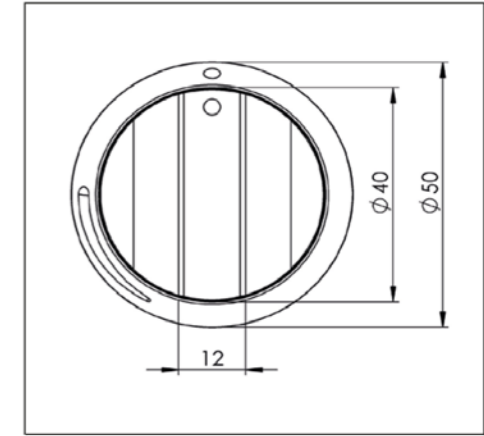

### **Important**

- Minimal countertop depth: 600 mm
- Total height PITT unit incl. support bar set: 119 mm
- Countertop thickness: 4-35 mm
- The C-size is a **minimal** size

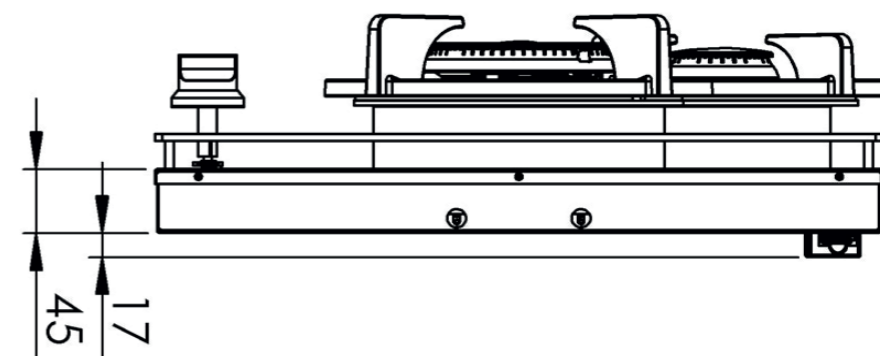
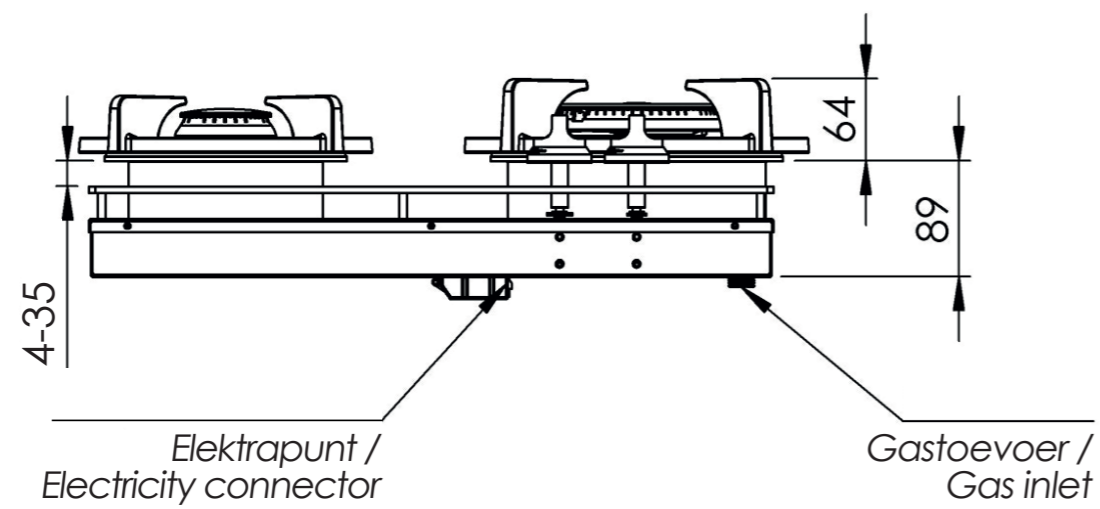
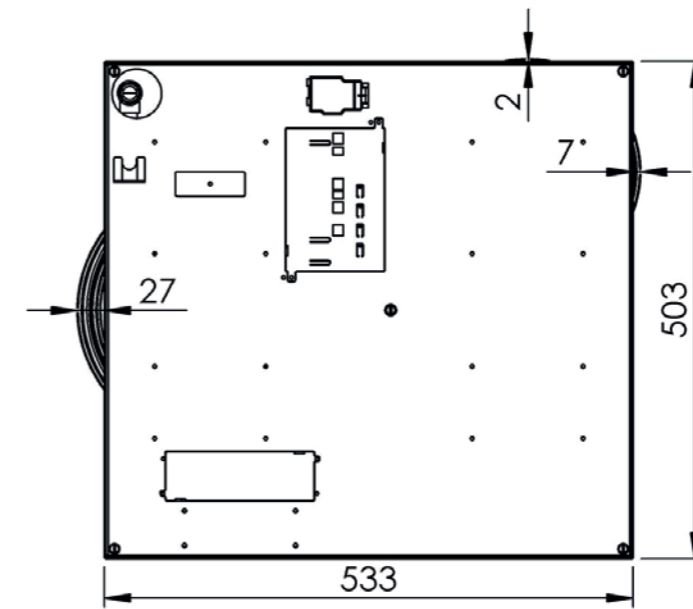
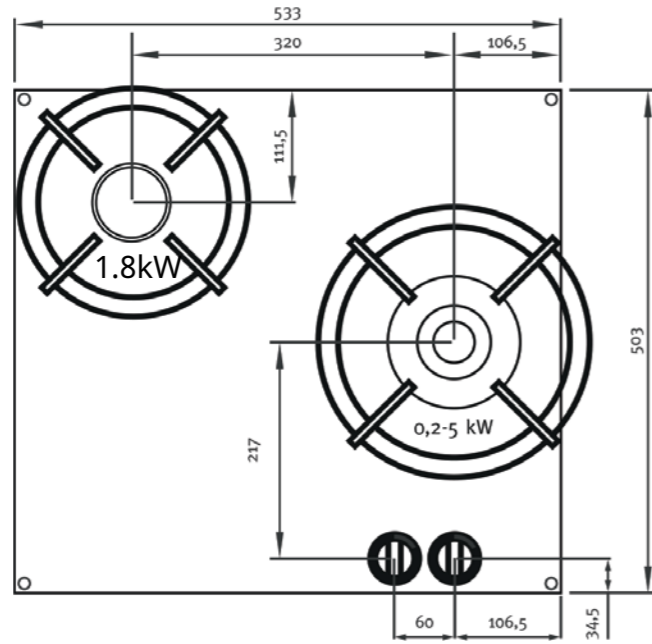

## Hole pattern

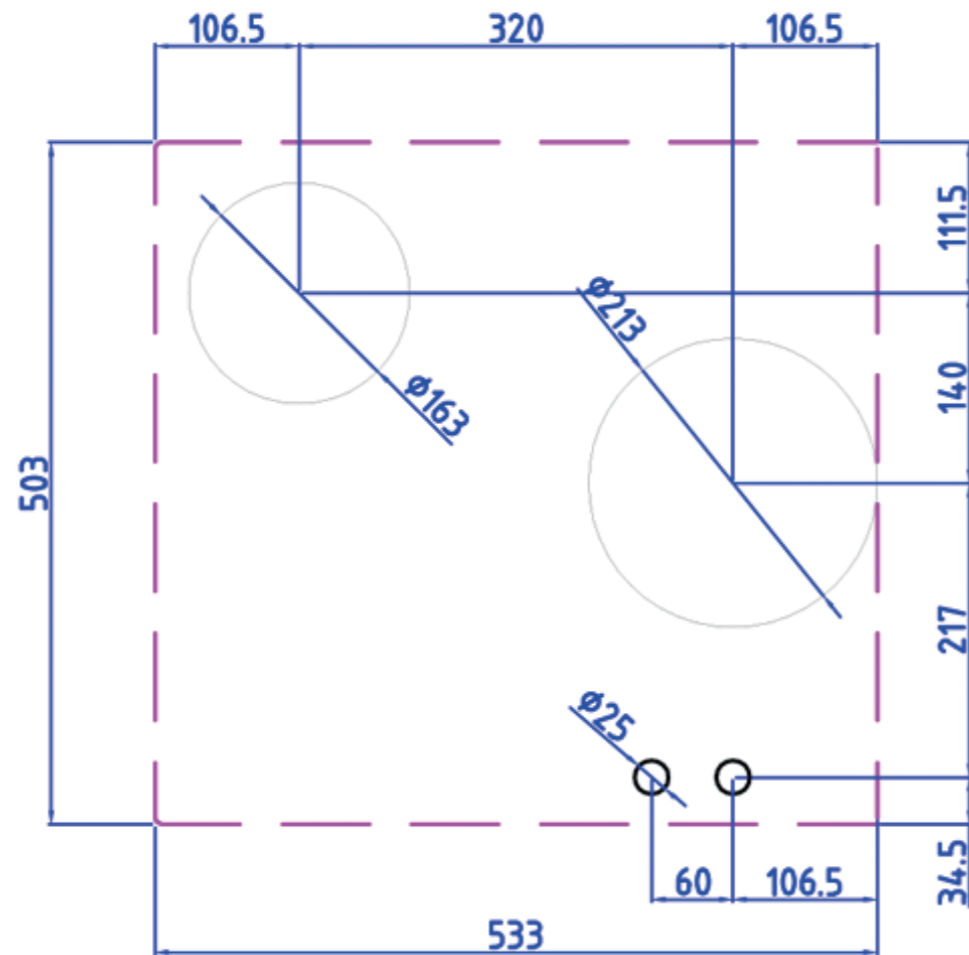

## Technical specifications

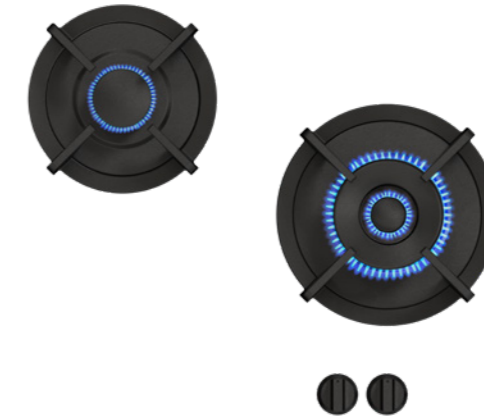

Model	Bennett Top Side
Type of burners	1x burner small (0,3 - 2 kW) 1x wok-/simmer burner (0,2 - 5 kW)
Editions	Professional (brass) Black (full black)
The controls	Top Side
Module dimensions (LxWxH)	503 x 533 x 89 mm
Automatic spark ignition	✓
Flame protection	✓
Weight	22 kg
Wok ring	✓
<b>Gas &amp; Electricity</b>	
Type of gas suitable	Natural gas, LPG (Bottled gas)
Type of gas connection	½" external threads
Position gas connection	Top corner, right
Voltage	220V-110V (default) / 1,5V (battery)
Cord length	1500 mm / 591/16"



Installation and handling instructions gas



Installation manual Top Side gas



User manual gas